



ENERJİ SAN. LTD. ŞTİ.

# LED ÜRÜN KATALOĞU

LED Product Catalogue



[www.licon.com.tr](http://www.licon.com.tr)

## TR

30 yılı aşkın elektronik sektöründe tecrübesi olan ekip; Verimli, uzun ömürlü, estetik yeni nesil aydınlatmanın elektronik chip malzemelerle mümkün olduğu bu çağımızda birikimini aydınlatma sektörüne odaklamıştır. Bu tecrübesini ürünlerine ve müşterilerine tam anlamıyla yansıtabilecek güvenilir bir markayla karşılarında çıkmaktan büyük gurur duymaktadır.

LİCON; ışığın canlılar üzerinde biyolojik, fiziksel ve ruhsal etkilerini, açık alan ve kapalı alan estetiklerini, kullanım alanları ve amaçlarına göre fonksiyonel aydınlatma standartlarını referans alarak ürünlerini dizayn etmektedir.

En verimli, estetik ,uzun ömürlü aydınlatma çözümleri üretmek için ARGE ve kalite yatırımlarına tecrübeli mühendisleriyle hız kesmeden devam eden, teknolojik ürünlerine her gün bir yenisini ilave eden dinamik ekip, aydınlatmanın adresini ve markasını LİCON'da toplamıştır.

Ürünler iki ana başlık altında gruplanmıştır.  
İç Aydınlatma: Ofisler, mağazalar, depolar, fabrika alanları, kapalı spor sahaları.

Dış Aydınlatma: Cadde, sokak, meydan, açık alanlar, park, bahçe, spor sahaları, tünel aydınlatmaları.

## EN

With over 30 years experience in the electronics industry team; efficient, long lasting and aesthetically pleasing as possible with the new generation of lighting in the era of the electronic chip material, the lighting industry has been focused on. This experience fully reflect the products and customers a reliable brand is proud to serve.

LİCON; with reference to the functional lighting standards:

The light on the living biological, physical and psychological effects, aesthetic indoor and outdoor use, place and purpose is to design products according to.

The most efficient, aesthetic and durable lighting solutions, to produce quality investments in R & D and experienced team continues full speed.

Every day by the addition of a new technological products, LİCON has been the adres and the brand of lighting.

Products are grouped under two main categories:  
Indoor Lighting: offices, shops, warehouses, factories, indoor sports arenas.

Outdoor Lighting: streets, open spaces, parks, gardens, sports fields, tunnel lighting.

# İÇİNDEKİLER

## CONTENTS

### YOL-CADDE AYDINLATMA SERİSİ

ROAD-STREET LIGHTING SERIES



### PARK-BAHÇE AYDINLATMA SERİSİ

PARK-GARDEN LIGHTING SERIES



**PROJEKTÖR  
AYDINLATMA SERİSİ**  
PROJECTOR LIGHTING SERIES



**KANOPI  
AYDINLATMA SERİSİ**  
CANOPY LIGHTING SERIES

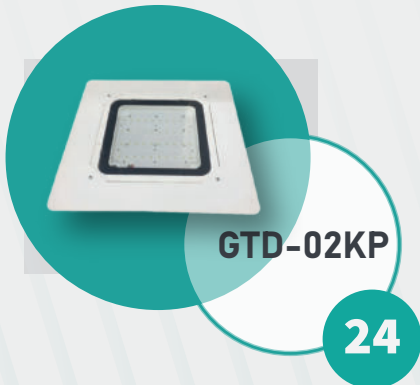

**DIŞ AYDINLATMA  
ÜRÜNLERİ 3 YIL  
GARANTİLİDİR.**

OUTDOOR LIGHTING PRODUCTS  
ARE WARRANTY 3 YEARS.

**YÜKSEK TAVAN-ENDÜSTRİYEL  
AYDINLATMA SERİSİ**  
HIGH BAY-INDUSTRIAL LIGHTING SERIES



## ASMATAVAN AYDINLATMA SERİSİ

SUSPENDED CEILING LIGHTING  
SERIES



GTI-AT

31

## SIVAÜSTÜ AYDINLATMA SERİSİ

SURFACE MOUNTED LIGHTING  
SERIES



GTI-SU

33

## ALÇIPAN AYDINLATMA SERİSİ

UNDER PLASTER LIGHTING  
SERIES



GTI-AP

35

## KLİPİN AYDINLATMA SERİSİ

CLIPIN LIGHTING SERIES



GTI-CP

37

## LİNEER AYDINLATMA SERİSİ

LINEER LIGHTING SERIES

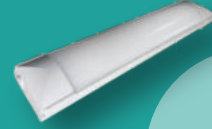

GTI-ET

39



GTI-ETY

40



GTI-ET01

41

**DOWNLIGHT**  
**AYDINLATMA SERİSİ**  
DOWNLIGHT LIGHTING SERIES

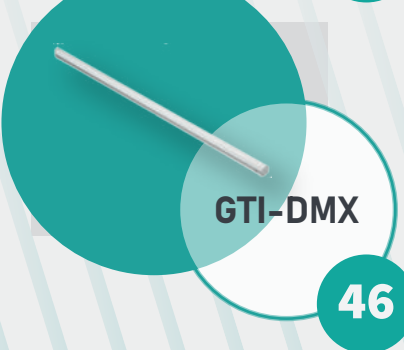
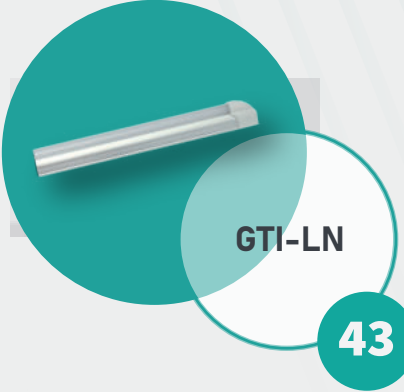

**ACİL**  
**AYDINLATMA SERİSİ**  
EMERGENCY LIGHTING SERIES



**İÇ AYDINLATMA**  
**ÜRÜNLERİ 5 YIL**  
**GARANTİLİDİR.**

INDOOR LIGHTING PRODUCTS  
ARE WARRANTY 5 YEARS.

**LICON**

ENERJİ SAN. LTD. ŞTİ.

**LED AYDINLATMA**  
**LED LIGHTING**

[www.licon.com.tr](http://www.licon.com.tr)





**CADDE AYDINLATMA SERİSİ**  
**STREET LIGHTING SERIES**

## CADDE AYDINLATMA SERİSİ STREET LIGHTING SERIES GTD-30S

GTD-30S30

GTD-30S40

GTD-30S50

GTD-30S60

GTD-30S75

GTD-30S90



### Teknik Özellikler - Technical Specifications

- Ürünün gövdesi; alüminyum enjeksiyon
- Mükemmel termal performans
- Ömür: >50.000 saat, PF: >95%
- 90 ° ayarlanabilir montaj açısı
- Giriş gerilimi : 220-240V Frekans: 50-60 Hz
- Renksel ger. ind. (CRI): >70
- Güç faktörü: >0,95
- 3 yıl garanti.
- Die-cast aluminium
- Excelant thermal performance
- Life: >50.000 h, PF:>95%
- Angle can be adjustable (90 °)
- Input voltage: 220-240V Frequency: 50-60 Hz
- Colour Ren. In(CRI): >70
- Power Fac. :>0,95
- 3 year warranty

Ürün Kodu Product Code	Güç Power (W)	Işık Akısı Lumen (lm)	Renk Sıcaklığı Color Temperatures (k)	Ürün Ağırlık Product Weight (kg)	Ürün Ebatları Product Sizes (mm)	Brüt Ağırlık Gross Weight (kg)	Kutu Ebatları Package Sizes (mm)
GTD-S-30S30	30	4050	3000-6500	3,5	292*485*98	4,2	300*490*100
GTD-S-30S40	40	5400	3000-6500	3,7	292*485*98	4,4	300*490*100
GTD-S-30S50	50	6750	3000-6500	3,7	292*485*98	4,4	300*490*100
GTD-S-30S60	60	8100	3000-6500	3,9	292*485*98	4,6	300*490*100
GTD-S-30S75	75	10125	3000-6500	4,1	292*485*98	4,8	300*490*100
GTD-S-30S90	90	12150	3000-6500	4,2	292*485*98	4,9	300*490*100

### Opsiyonlar - Options

Acil Durum Kiti: Var (1-3 saat)  
Emergency Kit: Yes (1-3 hours)  
Dimleme Protokolü : Uygun  
Dimming Protocol: Available

### Uygulama Alanları - Filed of Application



### Teknik Çizim - Technical Drawing

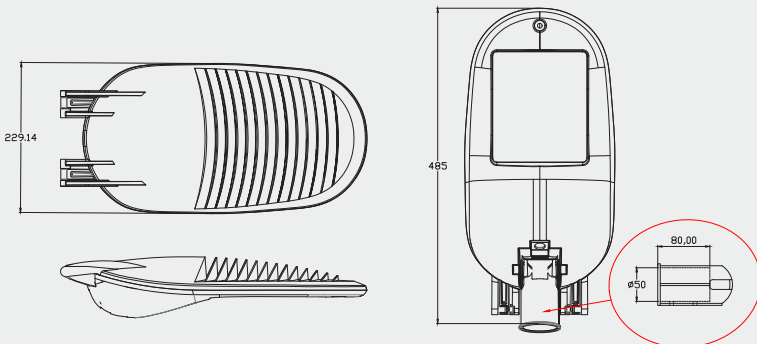

### Fotometrik Veri - Photometric Data

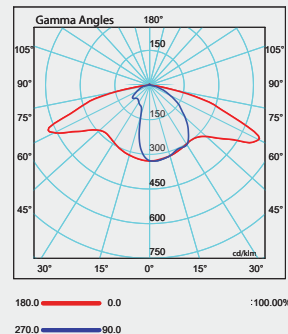

# CADDE AYDINLATMA SERİSİ STREET LIGHTING SERIES GTD-150S

GTD-150S85 / GTD-150S100 / GTD-150S110

GTD-150S125 / GTD-150S150

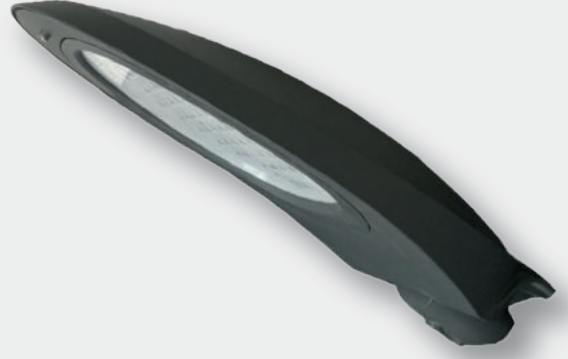

## Teknik Özellikler - Technical Specifications

- Ürünün gövdesi; alüminyum enjeksiyon
- Mükemmel termal performans
- Ömür: >50.000 saat, PF: >95%
- 90 ° ayarlanabilir montaj açısı
- Giriş gerilimi : 220-240V Frekans: 50-60 Hz
- Renksel ger. ind. (CRI): >70
- Güç faktörü: >0,95
- 3 yıl garanti.
- Die-cast aluminium
- Excelant thermal performance
- Life: >50.000 h, PF:>95%
- Angle can be adjustable (90 °)
- Input voltage: 220-240V Frequency: 50-60 Hz
- Colour Ren. In(CRI): >70
- Power Fac. :>0,95
- 3 year warranty

Ürün Kodu Product Code	Güç Power (W)	Işık Akısı Lumen (lm)	Renk Sıcaklığı Color Temperatures (k)	Ürün Ağırlık Product Weight (kg)	Ürün Ebatları Product Sizes (mm)	Brüt Ağırlık Gross Weight (kg)	Kutu Ebatları Package Sizes (mm)
GTD-S-150S85	85	11475	3000-6500	6,7	295*620*152	7,3	670*335*190
GTD-S-150S100	100	13500	3000-6500	6,7	295*620*152	7,3	670*335*190
GTD-S-150S110	110	14850	3000-6500	6,7	295*620*152	7,3	670*335*190
GTD-S-150S125	125	16875	3000-6500	6,7	295*620*152	7,3	670*335*190
GTD-S-150S150	150	20250	3000-6500	6,7	295*620*152	7,3	670*335*190

## Opsiyonlar - Options

Acil Durum Kiti: Var (1-3 saat)  
Emergency Kit: Yes (1-3 hours)  
Dimleme Protokolü : Uygun  
Dimming Protocol: Available

## Uygulama Alanları - Filed of Application



## Teknik Çizim - Technical Drawing

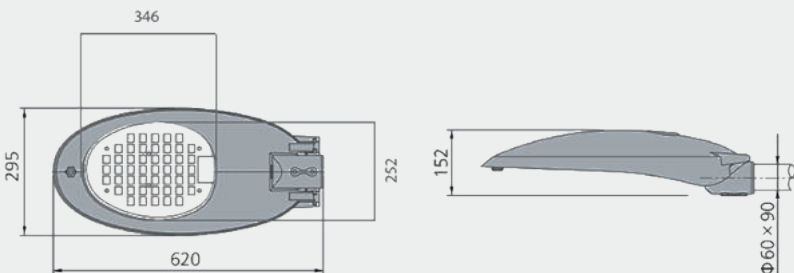

## Fotometrik Veri - Photometric Data

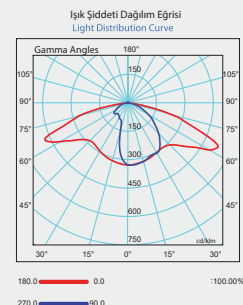

# CADDE AYDINLATMA SERİSİ STREET LIGHTING SERIES GTD-30L



GTD-30L150 / GTD-30L180 / GTD-30L200  
GTD-30L220 / GTD-30L250 / GTD-30L270  
GTD-30L300



## Teknik Özellikler - Technical Specifications

- Ürünün gövdesi; alüminyum enjeksiyon
- Mükemmel termal performans
- Ömür: >50.000 saat, PF: >95%
- 90 ° ayarlanabilir montaj açısı
- Giriş gerilimi : 220-240V Frekans: 50-60 Hz
- Renksel ger. ind. (CRI): >70
- Güç faktörü: >0,95
- 3 yıl garanti.
- Die-cast aluminium
- Excelant thermal performance
- Life: >50.000 h, PF:>95%
- Angle can be adjustable (90 °)
- Input voltage: 220-240V Frequency: 50-60 Hz
- Colour Ren. In(CRI): >70
- Power Fac. :>0,95
- 3 year warranty

Ürün Kodu Product Code	Güç Power (W)	Işık Akısı Lumen (lm)	Renk Sıcaklığı Color Temperatures (k)	Ürün Ağırlık Product Weight (kg)	Ürün Ebatları Product Sizes (mm)	Brüt Ağırlık Gross Weight (kg)	Kutu Ebatları Package Sizes (mm)
GTD-S-30SL150	150	20250	3000-6500	12,0	370*850*150	12,8	378*853*155
GTD-S-30L180	180	24300	3000-6500	12,2	370*850*150	13,0	378*853*155
GTD-S-30L200	200	27000	3000-6500	12,2	370*850*150	13,0	378*853*155
GTD-S-30L220	220	29700	3000-6500	12,5	370*850*150	13,4	378*853*155
GTD-S-30L250	250	33750	3000-6500	12,5	370*850*150	13,4	378*853*155
GTD-S-30L270	270	36450	3000-6500	12,6	370*850*150	13,6	378*853*155
GTD-S-30L300	300	40500	3000-6500	12,6	370*850*150	13,6	378*853*155

## Opsiyonlar - Options

Acil Durum Kiti: Var (1-3 saat)  
Emergency Kit: Yes (1-3 hours)  
Dimleme Protokolü : Uygun  
Dimming Protocol: Available

## Teknik Çizim - Technical Drawing

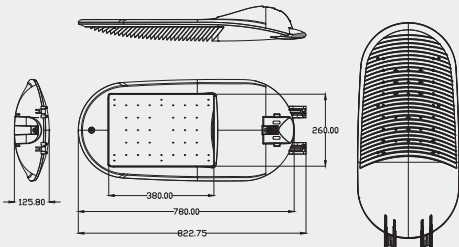

## Uygulama Alanları - Filed of Application



## Fotometrik Veri - Photometric Data

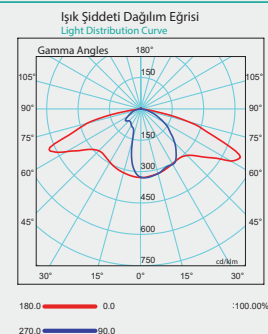

## SOLAR AYDINLATMA SOLAR LIGHTING



### Uygulama Alanları - Field of Application

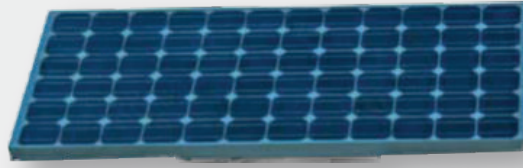

Performans	Batarya	Solar Batarya Bileşeni	Direk Yüksekliği	Işık Yüksekliği	Kontroller	Akım Modülü
Performance	Battery	Component Of Solar Battery	Height Of Pole	Light Height	Controller	Contant Current Module
30W	12V65AH	Tek kristalli silikon solar hücreler/ Mono-crystalline silicon solar cells	5m	4m	Işık kontrolü- Zaman kontrolü / Light control-Time control	10-20-30V 350mA±5%
40W	12V80AH	Tek kristalli silikon solar hücreler/ Mono-crystalline silicon solar cells	5m	4m	Işık kontrolü- Zaman kontrolü / Light control-Time control	10-20-30V 350mA±5%
50W	12V100AH	Tek kristalli silikon solar hücreler/ Mono-crystalline silicon solar cells	6m	5m	Işık kontrolü- Zaman kontrolü / Light control-Time control	10-20-30V 350mA±5%
60W	12V100AH	Tek kristalli silikon solar hücreler/ Mono-crystalline silicon solar cells	6m	5m	Işık kontrolü- Zaman kontrolü / Light control-Time control	10-20-30V 350mA±5%
70W	12V120AH	Tek kristalli silikon solar hücreler/ Mono-crystalline silicon solar cells	6m	5m	Işık kontrolü- Zaman kontrolü / Light control-Time control	10-20-30V 350mA±5%





**PARK BAHÇE AYDINLATMA SERİSİ**  
**PARK GARDEN LIGHTING SERIES**

## PARK BAHÇE AYDINLATMA SERİSİ PARK GARDEN LIGHTING SERIES GTD-02PB

GTD-PB02-30

GTD-PB02-40

GTD-PB02-50



### Teknik Özellikler - Technical Specifications

- Ürünün gövdesi; alüminyum enjeksiyon
- Mükemmel termal performans
- Ömür: >50.000 saat, PF: >95%
- Giriş gerilimi : 220-240V Frekans: 50-60 Hz
- Renksel ger. ind. (CRI): >70
- Güç faktörü: >0,95
- 3 yıl garanti.
- Die-cast aluminium
- Excelant thermal performance
- Life: >50.000 h, PF:>95%
- Input voltage: 220-240V Frequency: 50-60 Hz
- Colour Ren. In(CRI): >70
- Power Fac. :>0,95
- 3 year warranty

Ürün Kodu Product Code	Güç Power (W)	Işık Akısı Lumen (lm)	Renk Sıcaklığı Color Temperatures (k)	Ürün Ağırlık Product Weight (kg)	Ürün Ebatları Product Sizes (mm)	Brüt Ağırlık Gross Weight (kg)	Kutu Ebatları Package Sizes (mm)
GTD-PB02-30	30	12500	3000-6500	6,3	295*620*152	6,8	670*335*190
GTD-PB02-40	40	14000	3000-6500	6,3	295*620*152	6,8	670*335*190
GTD-PB02-50	50	15400	3000-6500	6,3	295*620*152	6,8	670*335*190

### Opsiyonlar - Options

Acil Durum Kiti: Var (1-3 saat)  
Emergency Kit: Yes (1-3 hours)  
Dimleme Protokolü : Uygun  
Dimming Protocol: Available

### Uygulama Alanları - Filed of Application



### Teknik Çizim - Technical Drawing

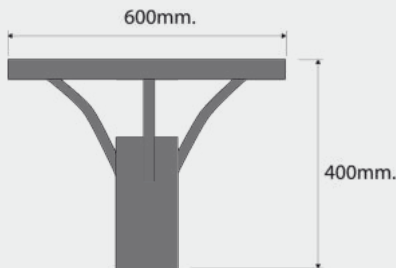

### Fotometrik Veri - Photometric Data

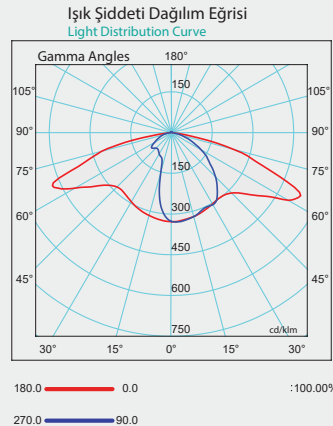

## PARK BAHÇE AYDINLATMA SERİSİ

## PARK GARDEN LIGHTING SERIES

# GTD-03PB



GTD-PB03-30 / GTD-PB03-40 / GTD-PB03-50 / GTD-PB03-60



### Teknik Özellikler - Technical Specifications

- Ürünün gövdesi; alüminyum enjeksiyon
- Mükemmel termal performans
- Ömür: >50.000 saat, PF: >95%
- Giriş gerilimi : 220-240V Frekans: 50-60 Hz
- Renksel ger. ind. (CRI): >70
- Güç faktörü: >0,95
- 3 yıl garanti.
- Die-cast aluminium
- Excelant thermal performance
- Life: >50.000 h, PF:>95%
- Input voltage: 220-240V Frequency: 50-60 Hz
- Colour Ren. In(CRI): >70
- Power Fac. :>0,95
- 3 year warranty

Ürün Kodu Product Code	Güç Power (W)	Işık Akısı Lumen (lm)	Renk Sıcaklığı Color Temperatures (k)	Ürün Ağırlık Product Weight (kg)	Ürün Ebatları Product Sizes (mm)	Brüt Ağırlık Gross Weight (kg)	Kutu Ebatları Package Sizes (mm)
GTD-PB03-30	30	4050	3000-6500	6,5	Ø 725 * 600	7,2	740*740*615
GTD-PB03-40	40	5400	3000-6500	6,5	Ø 725 * 600	7,2	740*740*615
GTD-PB03-50	50	6750	3000-6500	6,5	Ø 725 * 600	7,2	740*740*615
GTD-PB03-60	60	8100	3000-6500	6,5	Ø 725 * 600	7,2	740*740*615

### Opsiyonlar - Options

Acil Durum Kiti: Var (1-3 saat)  
Emergency Kit: Yes (1-3 hours)  
Dimleme Protokolü : Uygun  
Dimming Protocol: Available

### Uygulama Alanları - Filed of Application



### Teknik Çizim - Technical Drawing

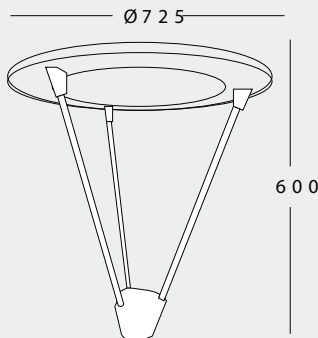

### Fotometrik Veri - Photometric Data

Işık Şiddeti Dağılım Eğrisi  
Light Distribution Curve

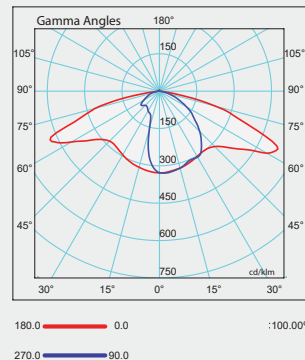



## PARK BAHÇE AYDINLATMA SERİSİ PARK GARDEN LIGHTING SERIES GTD-05PB

GTD-05PB-45

GTD-05PB-60

GTD-05PB-90



### Teknik Özellikler - Technical Specifications

- Ürünün gövdesi; alüminyum enjeksiyon
- Mükemmel termal performans
- Ömür: >50.000 saat, PF: >95%
- Giriş gerilimi : 220-240V Frekans: 50-60 Hz
- Renksel ger. ind. (CRI): >70
- Güç faktörü: >0,95
- 3 yıl garanti.
- Die-cast aluminium
- Excelant thermal performance
- Life: >50.000 h, PF:>95%
- Input voltage: 220-240V Frequency: 50-60 Hz
- Colour Ren. In(CRI): >70
- Power Fac. :>0,95
- 3 year warranty

Ürün Kodu Product Code	Güç Power (W)	Işık Akısı Lumen (lm)	Renk Sıcaklığı Color Temperatures (k)	Ürün Ağırlık Product Weight (kg)	Ürün Ebatları Product Sizes (mm)	Brüt Ağırlık Gross Weight (kg)	Kutu Ebatları Package Sizes (mm)
GTD-PB05-45	45	6075	3000-6500	11,0	450*396*82	11,7	570*570*300
GTD-PB05-60	60	8100	3000-6500	11,0	450*396*82	11,7	570*570*300
GTD-PB05-90	90	12150	3000-6500	11,0	450*396*82	11,7	570*570*300

### Opsiyonlar - Options

Acil Durum Kiti: Var (1-3 saat)  
Emergency Kit: Yes (1-3 hours)  
Dimleme Protokolü : Uygun  
Dimming Protocol: Available

### Uygulama Alanları - Filed of Application



### Teknik Çizim - Technical Drawing

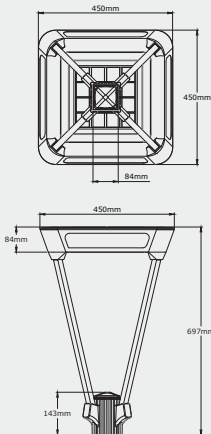

Armatürün ana gövde kısmında isteğe bağlı RGB aydınlatması ya da Dmx kontrolü  
Optional RGB lighting or DMX control on the main body part of the luminaire

### Fotometrik Veri - Photometric Data

Işık Şiddeti Dağılım Eğrisi  
Light Distribution Curve

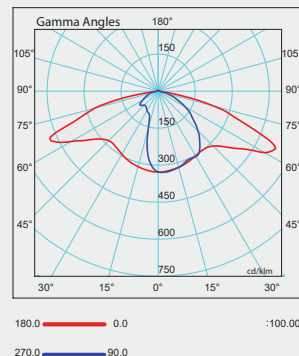

# PARK BAHÇE AYDINLATMA SERİSİ

## PARK GARDEN LIGHTING SERIES

### GTD-05PB

**Direk; 3m yüksekliğinde**

Pole; 3m high

**iki ayrı alüminyum 80x80 mm ve 120x120mm kare profil**

Two separate aluminum 80x80 mm and 120x120mm square profiles

**Cidar kalınlığı 2-3 mm alüminyum**

Thickness 2-3 mm aluminum

**Direk elektrostatik polyester toz boyama ile boyalı**

Painted with direct electrostatic polyester powder painting

**İsteğe bağlı olarak direğin dört taraflı, direk boyunca DMX kontrolü**

DMX control on all four sides of the pole, optionally along the pole

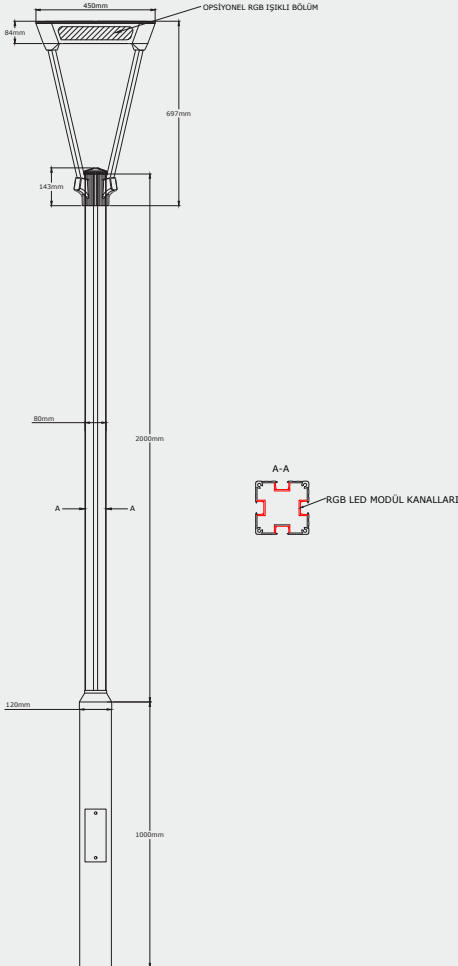

# PARK BAHÇE AYDINLATMA SERİSİ

## PARK GARDEN LIGHTING SERIES

### GTD-PB310Cx2



GTD-PB310C20x2 / GTD-PB310C30x2 / GTD-PB310C40x2



#### Teknik Özellikler - Technical Specifications

- Ürünün gövdesi; alüminyum enjeksiyon
- Mükemmel termal performans
- Ömür: >50.000 saat, PF: >95%
- Giriş gerilimi : 220-240V Frekans: 50-60 Hz
- Renksel ger. ind. (CRI): >70
- Güç faktörü: >0,95
- 3 yıl garanti.
- Die-cast aluminium
- Excelant thermal performance
- Life: >50.000 h, PF:>95%
- Input voltage: 220-240V Frequency: 50-60 Hz
- Colour Ren. In(CRI): >70
- Power Fac. :>0,95
- 3 year warranty

Ürün Kodu Product Code	Güç Power (W)	Işık Akısı Lumen (lm)	Renk Sıcaklığı Color Temperatures (k)	Ürün Ağırlık Product Weight (kg)	Ürün Ebatları Product Sizes (mm)	Brüt Ağırlık Gross Weight (kg)	Kutu Ebatları Package Sizes (mm)
GTD-PB310C-20x2	40	5400	3000-6500	6	Ø 310 * 50	6,5	570*570*300
GTD-PB310C-30x2	60	8100	3000-6500	6	Ø 310 * 50	6,5	570*570*300
GTD-PB310C-40x2	80	10800	3000-6500	6	Ø 310 * 50	6,5	570*570*300

#### Opsiyonlar - Options

Acil Durum Kiti: Var (1-3 saat)  
Emergency Kit: Yes (1-3 hours)  
Dimleme Protokolü : Uygun  
Dimming Protocol: Available

#### Uygulama Alanları - Filed of Application



#### Fotometrik Veri - Photometric Data

Işık Şiddeti Dağılım Eğrisi  
Light Distribution Curve

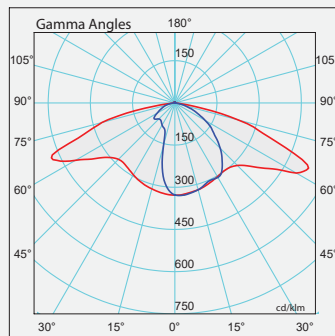

180.0 — 0.0 :100.00%  
270.0 — 90.0

## PARK BAHÇE AYDINLATMA SERİSİ PARK GARDEN LIGHTING SERIES GTD-PB310C



GTD-PB310C20 / GTD-PB310C30 / GTD-PB310C40



### Teknik Özellikler - Technical Specifications

- Ürünün gövdesi; alüminyum enjeksiyon
- Mükemmel termal performans
- Ömür: >50.000 saat, PF: >95%
- Giriş gerilimi : 220-240V Frekans: 50-60 Hz
- Renksel ger. ind. (CRI): >70
- Güç faktörü: >0,95
- 3 yıl garanti.
- Die-cast aluminium
- Excelant thermal performance
- Life: >50.000 h, PF:>95%
- Input voltage: 220-240V Frequency: 50-60 Hz
- Colour Ren. In(CRI): >70
- Power Fac. :>0,95
- 3 year warranty

Ürün Kodu Product Code	Güç Power (W)	Işık Akısı Lumen (lm)	Renk Sıcaklığı Color Temperatures (k)	Ürün Ağırlık Product Weight (kg)	Ürün Ebatları Product Sizes (mm)	Brüt Ağırlık Gross Weight (kg)	Kutu Ebatları Package Sizes (mm)
GTD-PB310C-20	20	2700	3000-6500	3	Ø 310 * 50	3,5	570*570*300
GTD-PB310C-30	30	4050	3000-6500	3	Ø 310 * 50	3,5	570*570*300
GTD-PB310C-40	40	5400	3000-6500	3	Ø 310 * 50	3,5	570*570*300

### Opsiyonlar - Options

Acil Durum Kiti: Var (1-3 saat)  
Emergency Kit: Yes (1-3 hours)  
Dimleme Protokolü : Uygun  
Dimming Protocol: Available

### Uygulama Alanları - Filed of Application



### Fotometrik Veri - Photometric Data

Işık Şiddeti Dağılım Eğrisi  
Light Distribution Curve

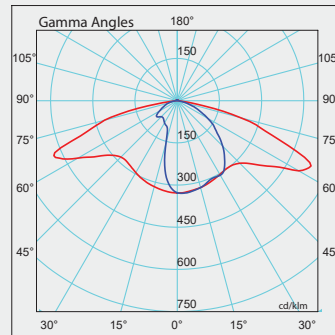

180.0 — 0.0 :100.00%  
270.0 — 90.0



**PROJEKTÖR AYDINLATMA SERİSİ**  
**PROJECTOR LIGHTING SERIES**

# PROJEKTÖR AYDINLATMA SERİSİ

## PROJECTOR LIGHTING SERIES

### GTD-03Px2

GTD-03Px2-700

GTD-03Px2-800

GTD-03Px2-900

GTD-03Px2-1000



#### Teknik Özellikler - Technical Specifications

- Ürünün gövdesi; alüminyum enjeksiyon
- Mükemmel termal performans
- Ömür: >50.000 saat, PF: >95%
- 360° ayarlanabilir montaj açısı
- 30°-60°-120° açı opsiyonu
- Giriş gerilimi : 220-240V Frekans: 50-60 Hz
- Renksel ger. ind. (CRI): >70
- Güç faktörü: >0,95
- 3 yıl garanti.
- Die-cast aluminium
- Excelant thermal performance
- Life: >50.000 h, PF:>95%
- Angle can be adjustable (360°)
- 30°-60°-120° angle option
- Input voltage: 220-240V Frequency: 50-60 Hz
- Colour Ren. In(CRI): >70
- Power Fac. :>0,95
- 3 year warranty

Ürün Kodu Product Code	Güç Power (W)	Işık Akısı Lumen (lm)	Renk Sıcaklığı Color Temperatures (k)	Ürün Ağırlık Product Weight (kg)	Ürün Ebatları Product Sizes (mm)	Brüt Ağırlık Gross Weight (kg)	Kutu Ebatları Package Sizes (mm)
GTD-03Px2-700	700	94500	3000-6500	40,0	800*490*200	41	820*510*220
GTD-03Px2-800	800	108000	3000-6500	40,0	800*490*200	41	820*510*220
GTD-03Px2-900	900	121500	3000-6500	40,0	800*490*200	41	820*510*220
GTD-03Px2-1000	1000	135000	3000-6500	40,0	800*490*200	41	820*510*220

#### Opsiyonlar - Options

Acil Durum Kiti: Var (1-3 saat)  
Emergency Kit: Yes (1-3 hours)

Dimleme Protokolü : Uygun  
Dimming Protocol: Available

#### Montaj Şekilleri - Mounting Styles



#### Uygulama Alanları - Filed of Application



#### Fotometrik Veri - Photometric Data

Işık Şiddeti Dağılım Eğrisi  
Light Distribution Curve

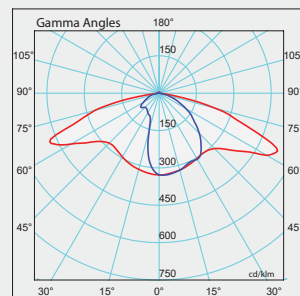

180.0 0.0 :100.00%  
270.0 90.0

# PROJEKTÖR AYDINLATMA SERİSİ

## PROJECTOR LIGHTING SERIES

### GTD-03P



GTD-03P-250

GTD-03P-300

GTD-03P-350

GTD-03P-400

GTD-03P-500

GTD-03P-600



#### Teknik Özellikler - Technical Specifications

- Ürünün gövdesi; alüminyum enjeksiyon
- Mükemmel termal performans
- Ömür: >50.000 saat, PF: >95%
- 360° ayarlanabilir montaj açısı
- 30°-60°-120° açı opsiyonu
- Giriş gerilimi : 220-240V Frekans: 50-60 Hz
- Renksel ger. ind. (CRI): >70
- Güç faktörü: >0,95
- 3 yıl garanti.
- Die-cast aluminium
- Excelant thermal performance
- Life: >50.000 h, PF:>95%
- Angle can be adjustable (360°)
- 30°-60°-120° angle option
- Input voltage: 220-240V Frequency: 50-60 Hz
- Colour Ren. In(CRI): >70
- Power Fac. :>0,95
- 3 year warranty

Ürün Kodu Product Code	Güç Power (W)	Işık Akısı Lumen (lm)	Renk Sıcaklığı Color Temperatures (k)	Ürün Ağırlık Product Weight (kg)	Ürün Ebatları Product Sizes (mm)	Brüt Ağırlık Gross Weight (kg)	Kutu Ebatları Package Sizes (mm)
GTD-03P-250	250	33750	3000-6500	13,0	390*490*200	14	410*510*220
GTD-03P-300	300	40500	3000-6500	13,0	390*490*200	14	410*510*220
GTD-03P-350	350	47250	3000-6500	13,0	390*490*200	14	410*510*220
GTD-03P-400	400	54000	3000-6500	13,0	390*490*200	14	410*510*220
GTD-03P-500	500	67500	3000-6500	13,0	390*490*200	14	410*510*220
GTD-PB03-600	600	81000	3000-6500	13,0	390*490*200	14	410*510*220

#### Opsiyonlar - Options

Acil Durum Kiti: Var (1-3 saat)  
Emergency Kit: Yes (1-3 hours)

Dimleme Protokolü : Uygun  
Dimming Protocol: Available

#### Teknik Çizim - Technical Drawing

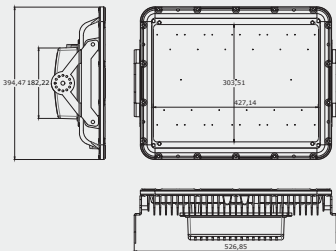

#### Uygulama Alanları - Filed of Application



#### Fotometrik Veri - Photometric Data

Işık Şiddeti Dağılım Eğrisi  
Light Distribution Curve

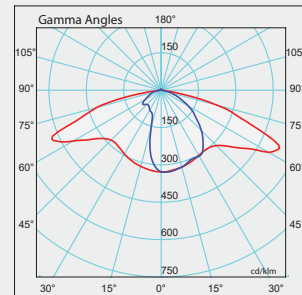

180.0 0.0 :100.00%  
270.0 90.0

## PROJEKTÖR AYDINLATMA SERİSİ PROJECTOR LIGHTING SERIES GTD-05P



GTD-05P-65

GTD-05P-80

GTD-05P-90

GTD-05P-100

GTD-05P-120

GTD-05P-150

GTD-05P-180

GTD-05P-200



IP  
67

IK  
08



RoHS



### Teknik Özellikler - Technical Specifications

- Ürünün gövdesi; alüminyum enjeksiyon
- Mükemmel termal performans
- Ömür: >50.000 saat, PF: >95%
- 360 ° ayarlanabilir montaj açısı
- 30°-60°-90°-120° açı opsiyonu
- Giriş gerilimi : 220-240V Frekans: 50-60 Hz
- Renksel ger. ind. (CRI): >70
- Güç faktörü: >0,95
- 3 yıl garanti.
- Die-cast aluminium
- Excelant thermal performance
- Life: >50.000 h, PF:>95%
- Angle can be adjustable (360°)
- 30°-60°-90°-120° angle option
- Input voltage: 220-240V Frequency: 50-60 Hz
- Colour Ren. In(CRI): >70
- Power Fac. :>0,95
- 3 year warranty

Ürün Kodu Product Code	Güç Power (W)	Işık Akısı Lumen (lm)	Renk Sıcaklığı Color Temperatures (k)	Ürün Ağırlık Product Weight (kg)	Ürün Ebatları Product Sizes (mm)	Brüt Ağırlık Gross Weight (kg)	Kutu Ebatları Package Sizes (mm)
GTD-05P-65	65	8775	3000-6500	7,2	330*330*60	7,5	400*400*130
GTD-05P-80	80	10800	3000-6500	7,2	330*330*60	7,5	400*400*130
GTD-05P-90	90	12150	3000-6500	7,2	330*330*60	7,5	400*400*130
GTD-05P-100	100	13500	3000-6500	7,2	330*330*60	7,5	400*400*130
GTD-05P-120	120	16200	3000-6500	7,2	330*330*60	7,5	400*400*130
GTD-05P-150	150	20250	3000-6500	7,2	330*330*60	7,5	400*400*130
GTD-05P-180	180	24300	3000-6500	7,2	330*330*60	7,5	400*400*130
GTD-05P-200	200	27000	3000-6500	7,2	330*330*60	7,5	400*400*130

### Opsiyonlar - Options

Acil Durum Kiti: Var (1-3 saat)  
Emergency Kit: Yes (1-3 hours)  
Dimleme Protokolü : Uygun  
Dimming Protocol: Available

### Teknik Çizim - Technical Drawing

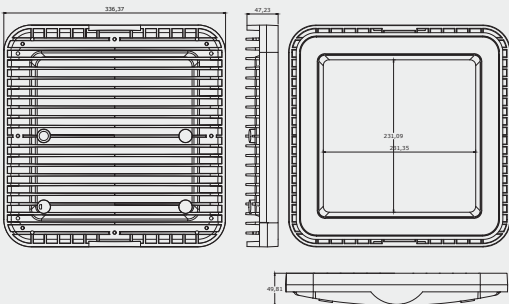

### Uygulama Alanları - Filed of Application



ŞEHİR İÇİ  
YOLLAR



MEYDANLAR



BİNA ÇEVRESİ



PARKLAR



AÇIK  
OTOPARKLAR

### Fotometrik Veri - Photometric Data

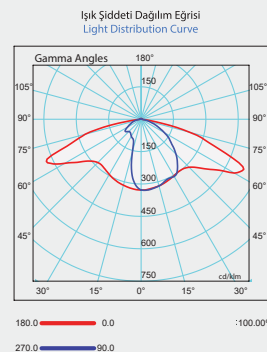





**KANOPI AYDINLATMA SERİSİ**  
**CANOPY LIGHTING SERIES**

# KANOPI AYDINLATMA SERİSİ

## CANOPY LIGHTING SERIES

### GTD-02KP

GTD-02KP-70 / GTD-02KP-90 / GTD-02KP-120

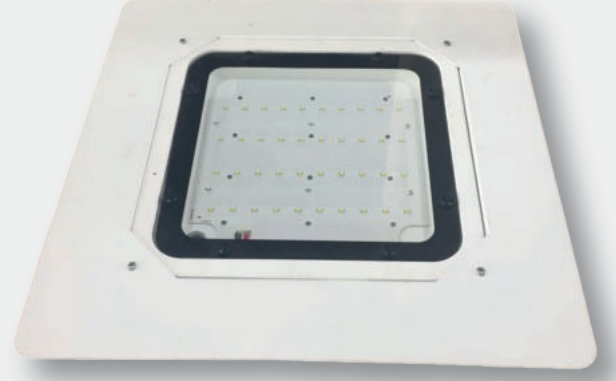

#### Teknik Özellikler - Technical Specifications

- Ürünün gövdesi; alüminyum enjeksiyon
- Mükemmel termal performans
- Ömür: >50.000 saat, PF: >95%
- Giriş gerilimi : 220-240V Frekans: 50-60 Hz
- Renksel ger. ind. (CRI): >70
- Güç faktörü: >0,95
- 3 yıl garanti.
- Die-cast aluminium
- Excelant thermal performance
- Life: >50.000 h, PF:>95%
- Input voltage: 220-240V Frequency: 50-60 Hz
- Colour Ren. In(CRI): >70
- Power Fac. :>0,95
- 3 year warranty

Ürün Kodu Product Code	Güç Power (W)	Işık Akısı Lumen (lm)	Renk Sıcaklığı Color Temperatures (k)	Ürün Ağırlık Product Weight (kg)	Ürün Ebatları Product Sizes (mm)	Brüt Ağırlık Gross Weight (kg)	Kutu Ebatları Package Sizes (mm)
GTD-02KP-70	70	9450	3000-6500	4,3	330*330*60	4,8	350*350*80
GTD-02KP-90	90	12150	3000-6500	4,5	330*330*60	5,0	350*350*80
GTD-02KP-120	120	16200	3000-6500	4,8	330*330*60	5,3	350*350*80

#### Opsiyonlar - Options

Acil Durum Kiti: Var (1-3 saat)  
Emergency Kit: Yes (1-3 hours)  
Dimleme Protokolü : Uygun  
Dimming Protocol: Available

#### Teknik Çizim - Technical Drawing

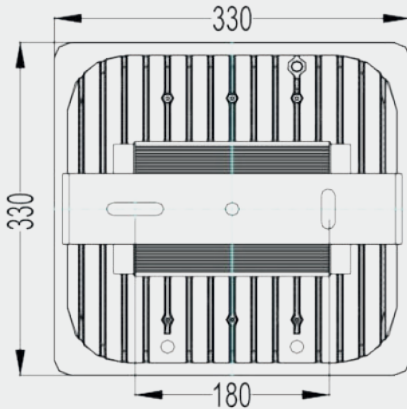

#### Uygulama Alanları - Field of Application



#### Fotometrik Veri - Photometric Data

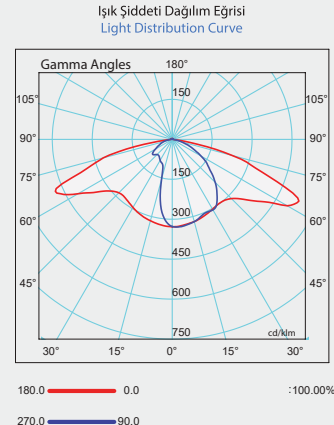

# KANOPI AYDINLATMA SERİSİ

## CANOPY LIGHTING SERIES

### GTD-05KP

GTD-05KP-70 / GTD-05KP-90 / GTD-05KP-100 / GTD-05KP-125

GTD-05KP-150



#### Teknik Özellikler - Technical Specifications

- Ürünün gövdesi; alüminyum enjeksiyon
- Mükemmel termal performans
- Ömür: >50.000 saat, PF: >95%
- Giriş gerilimi : 220-240V Frekans: 50-60 Hz
- Renksel ger. ind. (CRI): >70
- Güç faktörü: >0,95
- 3 yıl garanti.
- Die-cast aluminium
- Excelant thermal performance
- Life: >50.000 h, PF:>95%
- Input voltage: 220-240V Frequency: 50-60 Hz
- Colour Ren. In(CRI): >70
- Power Fac. :>0,95
- 3 year warranty

Ürün Kodu Product Code	Güç Power (W)	Işık Akısı Lumen (lm)	Renk Sıcaklığı Color Temperatures (k)	Ürün Ağırlık Product Weight (kg)	Ürün Ebatları Product Sizes (mm)	Brüt Ağırlık Gross Weight (kg)	Kutu Ebatları Package Sizes (mm)
GTD-KP05-70	70	9450	3000-6500	7,7	330*330*60	8,0	350*350*80
GTD-KP05-90	90	12150	3000-6500	7,7	330*330*60	8,0	350*350*80
GTD-KP05-100	100	13500	3000-6500	7,7	330*330*60	8,0	350*350*80
GTD-KP05-125	125	16875	3000-6500	7,7	330*330*60	8,0	350*350*80
GTD-KP05-150	150	20250	3000-6500	7,7	330*330*60	8,0	350*350*80

#### Opsiyonlar - Options

Acil Durum Kiti: Var (1-3 saat)  
Emergency Kit: Yes (1-3 hours)  
Dimleme Protokolü : Uygun  
Dimming Protocol: Available

#### Teknik Çizim - Technical Drawing

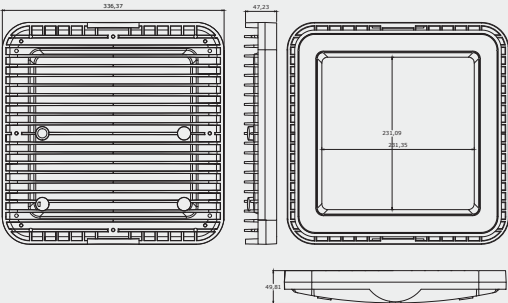

#### Uygulama Alanları - Field of Application



#### Fotometrik Veri - Photometric Data

Işık Şiddeti Dağılım Eğrisi  
Light Distribution Curve

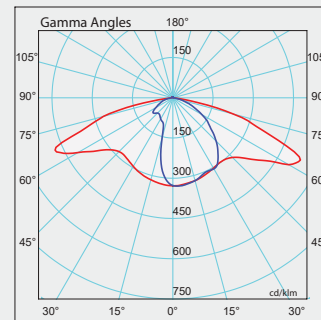



**YÜKSEK TAVAN AYDINLATMA SERİSİ**  
**HIGH BAY LIGHTING SERIES**

# YÜKSEK TAVAN AYDINLATMA SERİSİ HIGH BAY LIGHTING SERIES GTI-HB (30-60 Lensli)



GTI-HB15-30 / GTI-HB30-60 / GTI-HB60-110 / GTI-HB90-160



## Teknik Özellikler - Technical Specifications

- Ürünün gövdesi; alüminyum enjeksiyon
- Mükemmel termal performans
- Ömür: >50.000 saat, PF: >95%
- Giriş gerilimi : 220-240V Frekans: 50-60 Hz
- Renksel ger. ind. (CRI): >70
- Güç faktörü: >0,95
- 3 yıl garanti.
- Die-cast aluminium
- Excelant thermal performance
- Life: >50.000 h, PF:>95%
- Input voltage: 220-240V Frequency: 50-60 Hz
- Colour Ren. In(CRI): >70
- Power Fac. :>0,95
- 3 year warranty

Ürün Kodu Product Code	Güç Power (W)	Işık Akısı Lumen (lm)	Renk Sıcaklığı Color Temperatures (k)	Ürün Ağırlık Product Weight (kg)	Ürün Ebatları Product Sizes (mm)	Brüt Ağırlık Gross Weight (kg)	Kutu Ebatları Package Sizes (mm)
GTI-HB15-30	15	2025	3000-6500	0,531	305*70x56	0,55	550*120*65
GTI-HB30-60	30	4050	3000-6500	1,06	590x70x56	1,22	750*120*65
GTI-HB60-120	60	8100	3000-6500	2,125	1120x70x56	2,2	1350*120*65
GTI-HB90-160	90	12150	3000-6500	2,800	1620x210x48	3	1750*250*65

## Opsiyonlar - Options

Acil Durum Kiti: Var (1-3 saat)  
Emergency Kit: Yes (1-3 hours)  
Dimleme Protokolü : Uygun  
Dimming Protocol: Available

## Uygulama Alanları - Filed of Application



## Fotometrik Veri - Photometric Data

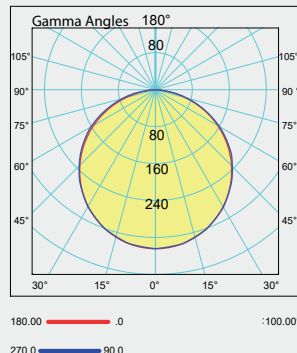

## YÜKSEK TAVAN AYDINLATMA SERİSİ HIGH BAY LIGHTING SERIES

### GTD-ETx2

GTD-ET50x2

GTI-ET60x2



#### Teknik Özellikler - Technical Specifications

- Ürünün gövdesi; alüminyum enjeksiyon
- Mükemmel termal performans
- Ömür: >50.000 saat, PF: >95%
- Giriş gerilimi : 220-240V Frekans: 50-60 Hz
- Renksel ger. ind. (CRI): >70
- Güç faktörü: >0,95
- 3 yıl garanti.
- Die-cast aluminium
- Excelant thermal performance
- Life: >50.000 h, PF:>95%
- Input voltage: 220-240V Frequency: 50-60 Hz
- Colour Ren. In(CRI): >70
- Power Fac. :>0,95
- 3 year warranty

Ürün Kodu Product Code	Güç Power (W)	Işık Akısı Lumen (lm)	Renk Sıcaklığı Color Temperatures (k)	Ürün Ağırlık Product Weight (kg)	Ürün Ebatları Product Sizes (mm)	Brüt Ağırlık Gross Weight (kg)	Kutu Ebatları Package Sizes (mm)
GTI-ET50x2	100	13500	3000-6500	3,8	1210*210x48	4,3	1260*250*65
GTI-ET60x2	120	16200	3000-6500	4,6	1600x210x48	5,2	1650*250*65

#### Opsiyonlar - Options

Acil Durum Kiti: Var (1-3 saat)  
Emergency Kit: Yes (1-3 hours)  
Dimleme Protokolü : Uygun  
Dimming Protocol: Available

#### Uygulama Alanları - Filed of Application



#### Fotometrik Veri - Photometric Data

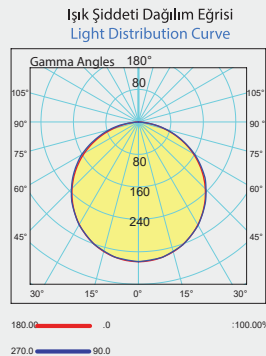

## YÜKSEK TAVAN AYDINLATMA SERİSİ HIGH BAY LIGHTING SERIES

### GTD-05ED (Montaj aparatı seçenekleri mevcuttur)



GTD-05ED-100 / GTD-05ED-125 / GTD-05ED-150 / GTD-05ED-180



#### Teknik Özellikler - Technical Specifications

- Ürünün gövdesi; alüminyum enjeksiyon
- Mükemmel termal performans
- Ömür: >50.000 saat, PF: >95%
- Giriş gerilimi : 220-240V Frekans: 50-60 Hz
- Renksel ger. ind. (CRI): >70
- Güç faktörü: >0,95
- 3 yıl garanti.
- Die-cast aluminium
- Excelant thermal performance
- Life: >50.000 h, PF:>95%
- Input voltage: 220-240V Frequency: 50-60 Hz
- Colour Ren. In(CRI): >70
- Power Fac. :>0,95
- 3 year warranty

Ürün Kodu Product Code	Güç Power (W)	Işık Akısı Lumen (lm)	Renk Sıcaklığı Color Temperatures (k)	Ürün Ağırlık Product Weight (kg)	Ürün Ebatları Product Sizes (mm)	Brüt Ağırlık Gross Weight (kg)	Kutu Ebatları Package Sizes (mm)
GTD-ED05-100	100	13500	3000-6500	7,2	330*330*60	7,9	400*400*130
GTD-ED05-125	125	16875	3000-6500	7,2	330*330*60	7,9	400*400*130
GTD-ED05-150	150	20250	3000-6500	7,2	330*330*60	7,9	400*400*130
GTD-ED05-180	180	24300	3000-6500	7,2	330*330*60	7,9	400*400*130
GTD-ED05-200	200	27000	3000-6500	7,2	330*330*60	7,9	400*400*130

#### Opsiyonlar - Options

Acil Durum Kiti: Var (1-3 saat)  
Emergency Kit: Yes (1-3 hours)  
Dimleme Protokolü : Uygun  
Dimming Protocol: Available

#### Teknik Çizim - Technical Drawing

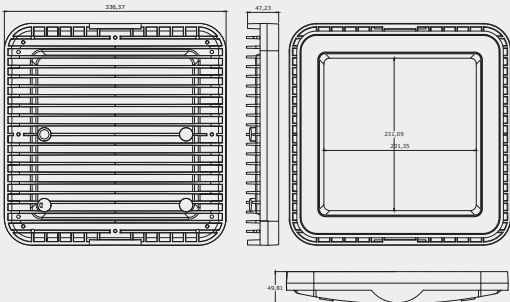

#### Uygulama Alanları - Field of Application



#### Fotometrik Veri - Photometric Data

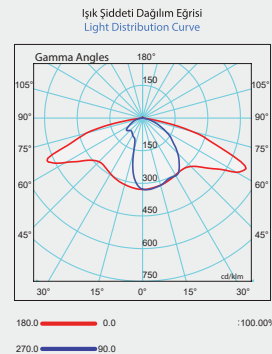



# ASMATAVAN AYDINLATMA SERİSİ SUSPENDED BAY LIGHTING SERIES



## ASMATAVAN AYDINLATMA SERİSİ SUSPENDED CEILING LIGHTING SERIES

### GTI-AT



GTI-AT9S

GTI-AT18S

GTI-AT36S

GTI-AT36S1

GTI-AT50S



### Teknik Özellikler - Technical Specifications

- Ürünün gövdesi; DKP sac gövde
- Mükemmel termal performans
- Ömür: >50.000 saat, PF: >95%
- Giriş gerilimi : 220-240V Frekans: 50-60 Hz
- Renksel ger. ind. (CRI): >70
- Güç faktörü: >0,95
- 3 yıl garanti.
- Die-cast DKP sheet metal body
- Excelant thermal performance
- Life: >50.000 h, PF:>95%
- Input voltage: 220-240V Frequency: 50-60 Hz
- Colour Ren. In(CRI): >70
- Power Fac. :>0,95
- 3 year warranty

Ürün Kodu Product Code	Güç Power (W)	Işık Akısı Lumen (lm)	Renk Sıcaklığı Color Temperatures (k)	Ürün Ağırlık Product Weight (kg)	Ürün Ebatları Product Sizes (mm)	Brüt Ağırlık Gross Weight (kg)	Kutu Ebatları Package Sizes (mm)
GTI-AT9S	9	1215	3000-6500	1,3	294x294x55	1,7	315x315x70
GTI-AT18S	18	2430	3000-6500	2,2	594x294x55	2,6	615x315x70
GTI-AT36S	36	4860	3000-6500	2,9	594x594x55	3,0	615x615x70
GTI-AT36S1	36	4860	3000-6500	2,9	1194x294x55	3,0	1220x315x70
GTD-AT50S	50	6750	3000-6500	2,9	594x594x55	3,0	615x615x70

### Opsiyonlar - Options

Acil Durum Kiti: Var (1-3 saat)  
Emergency Kit: Yes (1-3 hours)  
Dimleme Protokolü : Uygun  
Dimming Protocol: Available

### Uygulama Alanları - Field of Application



OTELLER



KORİDORLAR



ALIŞVERİŞİ  
MERKEZLERİ



MARKETLER



TOPLANTI  
SALONLARI

### Teknik Çizim - Technical Drawing



### Fotometrik Veri - Photometric Data

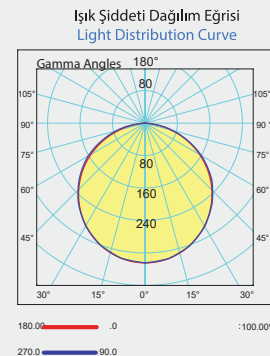



**SIVAÜSTÜ AYDINLATMA SERİSİ**  
**SURFACE MOUNTED LIGHTING SERIES**

## SIVAÜSTÜ AYDINLATMA SERİSİ SURFACE MOUNTED LIGHTING SERIES

### GTI-SU

GTI-SU9S

GTI-SU18S

GTI-SU36S

GTI-SU36S1

GTI-SU50S



#### Teknik Özellikler - Technical Specifications

- Ürünün gövdesi; DKP sac gövde
- Mükemmel termal performans
- Ömür: >50.000 saat, PF: >95%
- Giriş gerilimi : 220-240V Frekans: 50-60 Hz
- Renksel ger. ind. (CRI): >70
- Güç faktörü: >0,95
- 3 yıl garanti.
- Die-cast DKP sheet metal body
- Excelant thermal performance
- Life: >50.000 h, PF:>95%
- Input voltage: 220-240V Frequency: 50-60 Hz
- Colour Ren. In(CRI): >70
- Power Fac. :>0,95
- 3 year warranty

Ürün Kodu Product Code	Güç Power (W)	Işık Akısı Lumen (lm)	Renk Sıcaklığı Color Temperatures (k)	Ürün Ağırlık Product Weight (kg)	Ürün Ebatları Product Sizes (mm)	Brüt Ağırlık Gross Weight (kg)	Kutu Ebatları Package Sizes (mm)
GTI-SU9S	9	1215	3000-6500	1,3	300x300x55	1,5	315x315x80
GTI-SU18S	18	2430	3000-6500	2,7	600x300x65	3,2	615x315x80
GTI-SU36S	36	4860	3000-6500	4,2	600x600x65	4,6	615x615x80
GTI-SU36S1	36	4860	3000-6500	4,2	1200x300x65	4,6	1220x315x80
GTD-SU50S	50	6750	3000-6500	4,2	600x600x65	4,6	615x615x80

#### Opsiyonlar - Options

Acil Durum Kiti: Var (1-3 saat)  
Emergency Kit: Yes (1-3 hours)  
Dimleme Protokolü : Uygun  
Dimming Protocol: Available

#### Uygulama Alanları - Filed of Application



#### Teknik Çizim - Technical Drawing

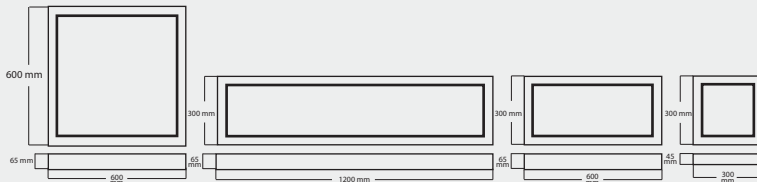

#### Fotometrik Veri - Photometric Data

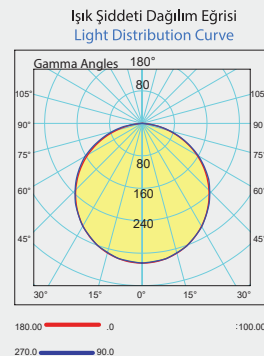



**ALÇIPAN AYDINLATMA SERİSİ**  
**UNDER PLASTER LIGHTING SERIES**

## ALÇIPAN AYDINLATMA SERİSİ UNDER PLASTER LIGHTING SERIES

### GTI-AP



GTI-AP9S

GTI-AP18S

GTI-AP36S

GTI-AP36S1

GTI-AP50S



#### Teknik Özellikler - Technical Specifications

- Ürünün gövdesi; DKP sac gövde
- Mükemmel termal performans
- Ömür: >50.000 saat, PF: >95%
- Giriş gerilimi : 220-240V Frekans: 50-60 Hz
- Renksel ger. ind. (CRI): >70
- Güç faktörü: >0,95
- 3 yıl garanti.
- Die-cast DKP sheet metal body
- Excelant thermal performance
- Life: >50.000 h, PF:>95%
- Input voltage: 220-240V Frequency: 50-60 Hz
- Colour Ren. In(CRI): >70
- Power Fac. :>0,95
- 3 year warranty

Ürün Kodu Product Code	Güç Power (W)	Işık Akısı Lumen (lm)	Renk Sıcaklığı Color Temperatures (k)	Ürün Ağırlık Product Weight (kg)	Ürün Ebatları Product Sizes (mm)	Brüt Ağırlık Gross Weight (kg)	Kutu Ebatları Package Sizes (mm)
GTI-AP9S	9	1215	3000-6500	1,3	300x300x55	1,7	315x315x70
GTI-AP18S	18	2430	3000-6500	2,2	594x294x55	2,6	615x315x70
GTI-AP36S	36	4860	3000-6500	2,9	594x594x55	3,3	615x615x70
GTI-AP36S1	36	4860	3000-6500	2,9	1194*294*55	3,3	1220x315x70
GTD-AP50S	50	6750	3000-6500	2,9	594x594x55	3,3	615x615x70

#### Opsiyonlar - Options

Acil Durum Kiti: Var (1-3 saat)  
Emergency Kit: Yes (1-3 hours)  
Dimleme Protokolü : Uygun  
Dimming Protocol: Available

#### Uygulama Alanları - Filed of Application



OTELLER



KORİDORLAR



ALIŞVERİŞ MERKEZLERİ



MARKETLER



TOPLANTI SALONLARI

#### Teknik Çizim - Technical Drawing

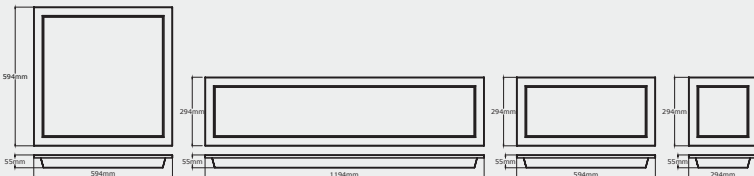

#### Fotometrik Veri - Photometric Data

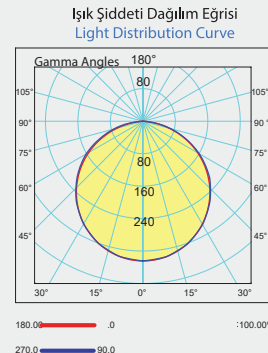

A wide-angle, low-angle shot of a modern office hallway. The ceiling is a white grid with numerous recessed rectangular lighting fixtures. The floor is highly reflective, showing the ceiling lights and the surrounding environment. The hallway is empty, with white walls and a series of white columns on the right side. The lighting is bright and even, creating a clean and professional atmosphere.

**KLİPİN AYDINLATMA SERİSİ**  
**CLIPIN LIGHTING SERIES**

# KLİPİN AYDINLATMA SERİSİ

## CLIPIN LIGHTING SERIES

### GTI-CP

GTI-CP9S

GTI-CP18S

GTI-CP36S

GTI-CP36S1

GTI-CP50S



### Teknik Özellikler - Technical Specifications

- Ürünün gövdesi; DKP sac gövde
- Mükemmel termal performans
- Ömür: >50.000 saat, PF: >95%
- Giriş gerilimi : 220-240V Frekans: 50-60 Hz
- Renksel ger. ind. (CRI): >70
- Güç faktörü: >0,95
- 3 yıl garanti.
- Die-cast DKP sheet metal body
- Excelant thermal performance
- Life: >50.000 h, PF:>95%
- Input voltage: 220-240V Frequency: 50-60 Hz
- Colour Ren. In(CRI): >70
- Power Fac. :>0,95
- 3 year warranty

Ürün Kodu Product Code	Güç Power (W)	Işık Akısı Lumen (lm)	Renk Sıcaklığı Color Temperatures (k)	Ürün Ağırlık Product Weight (kg)	Ürün Ebatları Product Sizes (mm)	Brüt Ağırlık Gross Weight (kg)	Kutu Ebatları Package Sizes (mm)
GTI-CP9S	9	1215	3000-6500	1,4	300x300x55	1,8	331x315x70
GTI-CP18S	18	2430	3000-6500	2,3	600x300x55	2,7	615x315x70
GTI-CP36S	36	4860	3000-6500	3,0	600x600x55	3,4	615x615x70
GTI-CP36S1	36	4860	3000-6500	3,0	1200*300*55	3,4	1215x315x70
GTD-CP50S	50	6750	3000-6500	3,0	600x600x55	3,4	615x615x70

### Opsiyonlar - Options

Acil Durum Kiti: Var (1-3 saat)  
Emergency Kit: Yes (1-3 hours)  
Dimleme Protokolü : Uygun  
Dimming Protocol: Available

### Uygulama Alanları - Filed of Application



OTELLER



KORİDORLAR



ALIŞVERİŞİ  
MERKEZLERİ



MARKETLER



TOPLANTI  
SALONLARI



HASTANELER

### Teknik Çizim - Technical Drawing

### Fotometrik Veri - Photometric Data

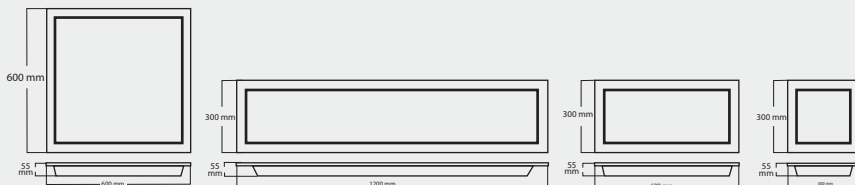

Işık Şiddeti Dağılım Eğrisi  
Light Distribution Curve

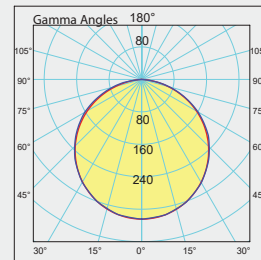

180.00 :0  
270.0 :90.0



**LİNEER AYDINLATMA SERİSİ**  
**LINEER LIGHTING SERIES**



# LİNEER AYDINLATMA SERİSİ

## LINEER LIGHTING SERIES

### GTI-ET (ALÜMİNYUM GÖVDE) IP54

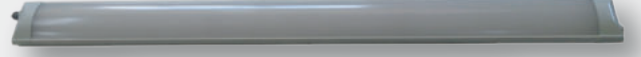

GTI-ET18-40

GTI-ET36-80

GTI-ET50-120

GTI-ET60-160



#### Teknik Özellikler - Technical Specifications

- Ürün gövdesi; alüminyum
- Hafif kompakt dizayn
- Ömür: >50.000 saat, PF: >95%
- Mükemmel termal performans
- Giriş gerilimi : 220-240V Frekans: 50-60 Hz
- Dahili acil kit opsiyonelli
- Güç faktörü: >0,95
- 3 yıl garanti.
- Body: aluminum
- Easy and compact design
- Life: >50.000 h, PF:>95%
- Excellent thermal performance
- Input voltage: 220-240V Frequency: 50-60 Hz
- Emergency kit optional
- Power Fac. :>0,95
- 3 year warranty

Ürün Kodu Product Code	Güç Power (W)	Işık Akısı Lumen (lm)	Renk Sıcaklığı Color Temperatures (k)	Ürün Ağırlık Product Weight (kg)	Ürün Ebatları Product Sizes (mm)	Brüt Ağırlık Gross Weight (kg)	Kutu Ebatları Package Sizes (mm)
GTI-ET18-40	18	2430	3000-6500	0,75	650x100x48	1,2	450x105x52
GTI-ET36-80	36	4860	3000-6500	1,3	813x100x48	1,6	850x105x52
GTI-ET50-120	50	6750	3000-6500	1,9	1210x100x48	2,2	1250x105x52
GTI-ET60-160	60	8100	3000-6500	2,5	1610x100x48	2,7	1650x105x52

#### Opsiyonlar - Options

Acil Durum Kiti: Var (1-3 saat)  
Emergency Kit: Yes (1-3 hours)  
Dimleme Protokolü : Uygun  
Dimming Protocol: Available

#### Teknik Çizim - Technical Drawing

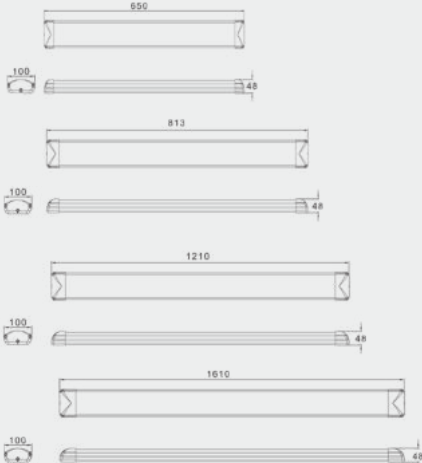

#### Uygulama Alanları - Field of Application



#### Fotometrik Veri - Photometric Data

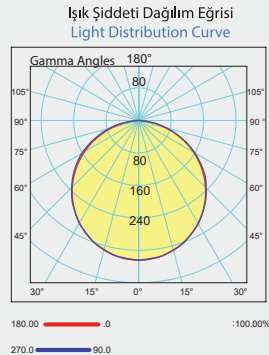

## LİNEER AYDINLATMA SERİSİ LINEER LIGHTING SERIES

### GTI-ETY (ALÜMİNYUM GÖVDE) IP54



GTI-ETY18

GTI-ETY36

GTI-ETY52

GTI-ETY65

GTI-ETY75

GTI-ETY90



#### Teknik Özellikler - Technical Specifications

- Ürünün gövdesi; alüminyum enjeksiyon
- Mükemmel termal performans
- Ömür: >50.000 saat, PF: >95%
- Giriş gerilimi : 220-240V Frekans: 50-60 Hz
- Renksel ger. ind. (CRI): >70
- Güç faktörü: >0,95
- 3 yıl garanti.
- Die-cast aluminium
- Excelant thermal performance
- Life: >50.000 h, PF:>95%
- Input voltage: 220-240V Frequency: 50-60 Hz
- Colour Ren. In(CRI): >70
- Power Fac. :>0,95
- 3 year warranty

Ürün Kodu Product Code	Güç Power (W)	Işık Akısı Lumen (lm)	Renk Sıcaklığı Color Temperatures (k)	Ürün Ağırlık Product Weight (kg)	Ürün Ebatları Product Sizes (mm)	Brüt Ağırlık Gross Weight (kg)	Kutu Ebatları Package Sizes (mm)
GTI-ETY18	18	2430	3000-6500	0,6	502x78,5x58	0,9	550x90x70
GTI-ETY36	36	4860	3000-6500	1,2	992x78,5x58	1,5	1040x90x70
GTI-ETY52	52	7020	3000-6500	1,9	1482x78.5x58	2,2	1530x90x70
GTI-ETY65	65	8775	3000-6500	2,0	1482x78.5x58	2,3	1530x90x70
GTI-ETY75	75	10125	3000-6500	2,3	2082x78.5x58	2,6	2130x90x70
GTI-ETY90	90	12150	3000-6500	2,5	2982x78.5x58	2,8	2930x90x70

#### Opsiyonlar - Options

Acil Durum Kiti: Var (1-3 saat)  
Emergency Kit: Yes (1-3 hours)  
Dimleme Protokolü : Uygun  
Dimming Protocol: Available

#### Teknik Çizim - Technical Drawing



#### Uygulama Alanları - Field of Application



#### Fotometrik Veri - Photometric Data

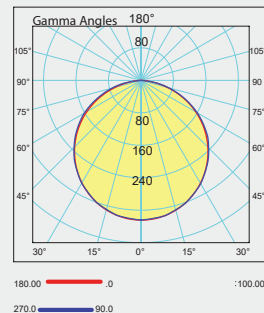

# LİNEER AYDINLATMA SERİSİ

## LINEER LIGHTING SERIES

### GTI-ET01 (PLASTİK GÖVDE) IP65



GTI-ET01-18-50 / GTI-ET01-35-100 / GTI-ET01-50-150



#### Teknik Özellikler - Technical Specifications

- Ürün gövdesi; plastik gövde
- Hafif kompakt dizayn
- Ömür: >50.000 saat, PF: >95%
- Mükemmel termal performans
- Giriş gerilimi : 220-240V Frekans: 50-60 Hz
- Dahili acil kit opsiyonelli
- Güç faktörü: >0,95
- 3 yıl garanti.
- Body: plastic body
- Easy and compact design
- Life: >50.000 h, PF:>95%
- Excellent thermal performance
- Input voltage: 220-240V Frequency: 50-60 Hz
- Emergency kit optional
- Power Fac. :>0,95
- 3 year warranty

Ürün Kodu Product Code	Güç Power (W)	Işık Akısı Lumen (lm)	Renk Sıcaklığı Color Temperatures (k)	Ürün Ağırlık Product Weight (kg)	Ürün Ebatları Product Sizes (mm)	Brüt Ağırlık Gross Weight (kg)	Kutu Ebatları Package Sizes (mm)
GTI-ET01-18-50	18	2430	3000-6500	0,75	500x60x51	1,05	550x70x55
GTI-ET01-35-100	35	4725	3000-6500	1,3	1000x60x51	1,6	1050x70x55
GTI-ET01-50-150	50	6750	3000-6500	2,2	1500x60x51	2,5	1550x70x55

#### Opsiyonlar - Options

Acil Durum Kiti: Var (1-3 saat)  
Emergency Kit: Yes (1-3 hours)  
Dimleme Protokolü : Uygun  
Dimming Protocol: Available

#### Uygulama Alanları - Filed of Application



#### Fotometrik Veri - Photometric Data

Işık Şiddeti Dağılım Eğrisi

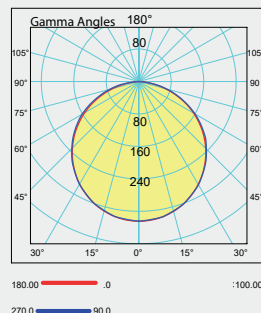

## LİNEER AYDINLATMA SERİSİ LINEER LIGHTING SERIES GTI-ETP (PLASTİK GÖVDE) IP65



GTI-ETP15

GTI-ETP30

GTI-ETP45



### Teknik Özellikler - Technical Specifications

- Ürünün gövdesi; plastik gövde
- Mükemmel termal performans
- Ömür: >50.000 saat, PF: >95%
- Giriş gerilimi : 220-240V Frekans: 50-60 Hz
- Renksel ger. ind. (CRI): >70
- Güç faktörü: >0,95
- 3 yıl garanti.
- Die-cast plastic body
- Excelant thermal performance
- Life: >50.000 h, PF:>95%
- Input voltage: 220-240V Frequency: 50-60 Hz
- Colour Ren. In(CRI): >70
- Power Fac. :>0,95
- 3 year warranty

Ürün Kodu Product Code	Güç Power (W)	Işık Akısı Lumen (lm)	Renk Sıcaklığı Color Temperatures (k)	Ürün Ağırlık Product Weight (kg)	Ürün Ebatları Product Sizes (mm)	Brüt Ağırlık Gross Weight (kg)	Kutu Ebatları Package Sizes (mm)
GTI-ETP15	15	2025	3000-6500	1,3	676*94*95	2,0	700*100*100
GTI-ETP30	30	4050	3000-6500	2,0	1283*94*95	2,5	1300*100*100
GTI-ETP45	45	6075	3000-6500	2,1	1283*94*95	2,6	1300*100*100

### Opsiyonlar - Options

Acil Durum Kiti: Var (1-3 saat)  
Emergency Kit: Yes (1-3 hours)  
Dimleme Protokolü : Uygun  
Dimming Protocol: Available

### Uygulama Alanları - Filed of Application



### Teknik Çizim - Technical Drawing

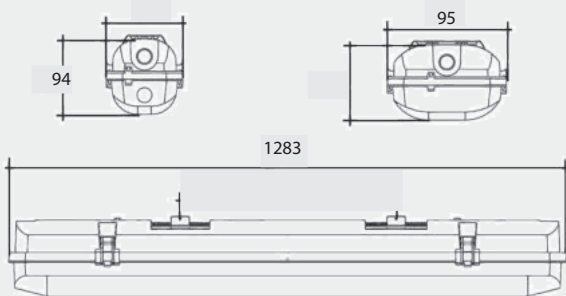

#### MANDAL/ FASTENER

-Paslanmaz Çelik / Stainless Steel  
-Yaylanma Özelliği ile Kolay ve Pratik  
Montaj / Easy and practical installation with  
biasig Feature  
-0,50 mm Kalınlık / 0,50 mm Thickness

#### TAVAN TAŞIYICI / CEILING CARRIER

-Paslanmaz Çelik / Stainless Steel  
-Yaylanma Özelliği ile Kolay ve Pratik  
Montaj / Easy and practical installation with  
biasig Feature  
-0,60 mm Kalınlık / 0,60 mm Thickness

#### RAKOR / GLAND

-Hammedde / Raw Material :Polyamid/ Polyamide  
-Koruma Sınıfı / Protection Class :IP 68  
-Isı Direnci / Heat Resistance :-30°C+80°C

# LİNEER AYDINLATMA SERİSİ

## LINEER LIGHTING SERIES

### GTI-LN

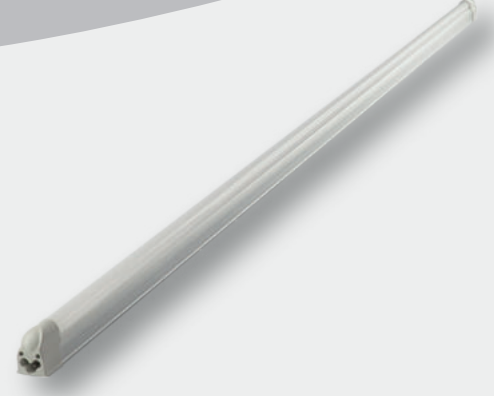

GTI-LN9-60

GTI-LN18-60



#### Teknik Özellikler - Technical Specifications

- Ürünün gövdesi; alüminyum enjeksiyon
- Mükemmel termal performans
- Ömür: >50.000 saat, PF: >95%
- Giriş gerilimi : 220-240V Frekans: 50-60 Hz
- Renksel ger. ind. (CRI): >70
- Güç faktörü: >0,95
- 3 yıl garanti.
- Die-cast aluminium
- Excelant thermal performance
- Life: >50.000 h, PF:>95%
- Input voltage: 220-240V Frequency: 50-60 Hz
- Colour Ren. In(CRI): >70
- Power Fac. :>0,95
- 3 year warranty

Ürün Kodu Product Code	Güç Power (W)	Işık Akısı Lumen (lm)	Renk Sıcaklığı Color Temperatures (k)	Ürün Ağırlık Product Weight (kg)	Ürün Ebatları Product Sizes (mm)	Brüt Ağırlık Gross Weight (kg)	Kutu Ebatları Package Sizes (mm)
GTI-LN9-60	9	1215	3000-6500	0,5	813x25x35	0,7	850x30x40
GTI-LN18-60	18	2430	3000-6500	0,9	1210x25x35	1,2	1230x30x40

#### Opsiyonlar - Options

Acil Durum Kiti: Var (1-3 saat)  
Emergency Kit: Yes (1-3 hours)  
Dimleme Protokolü : Uygun  
Dimming Protocol: Available

#### Uygulama Alanları - Filed of Application



#### Teknik Çizim - Technical Drawing

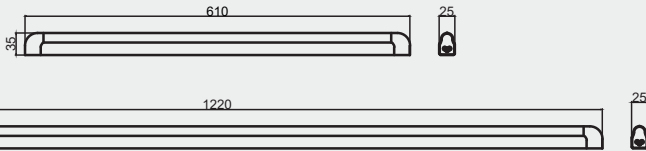

#### Fotometrik Veri - Photometric Data

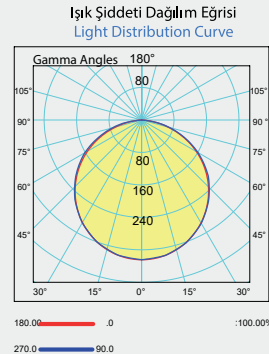

## LİNEER AYDINLATMA SERİSİ LINEER LIGHTING SERIES GTI-LN-S

GTI-LN-S18-50

GTI-LN-S36-120

GTI-LN-S52-150



### Teknik Özellikler - Technical Specifications

- Ürünün gövdesi; alüminyum enjeksiyon
- Mükemmel termal performans
- Ömür: >50.000 saat, PF: >95%
- Giriş gerilimi : 220-240V Frekans: 50-60 Hz
- Renksel ger. ind. (CRI): >70
- Güç faktörü: >0,95
- 3 yıl garanti.
- Die-cast aluminium
- Excelant thermal performance
- Life: >50.000 h, PF:>95%
- Input voltage: 220-240V Frequency: 50-60 Hz
- Colour Ren. In(CRI): >70
- Power Fac. :>0,95
- 3 year warranty

Ürün Kodu Product Code	Güç Power (W)	Işık Akısı Lumen (lm)	Renk Sıcaklığı Color Temperatures (k)	Ürün Ağırlık Product Weight (kg)	Ürün Ebatları Product Sizes (mm)	Brüt Ağırlık Gross Weight (kg)	Kutu Ebatları Package Sizes (mm)
GTI-LN-S18-50	18	2430	3000-6500	0,5	510x62x50	0,7	550x65x55
GTI-LN-S36-120	36	4860	3000-6500	0,9	1210x62x50	1,2	1250x65x55
GTI-LN-S52-150	52	7020	3000-6500	1,5	1510x62x50	1,7	1550x65x55

### Opsiyonlar - Options

Acil Durum Kiti: Var (1-3 saat)  
Emergency Kit: Yes (1-3 hours)  
Dimleme Protokolü : Uygun  
Dimming Protocol: Available

### Uygulama Alanları - Filed of Application



OTELLER



KORİDORLAR



ALIŞVERİŞİ  
MERKEZLERİ



MARKETLER



TOPLANTI  
SALONLARI



HASTANELER

### Teknik Çizim - Technical Drawing



### Fotometrik Veri - Photometric Data

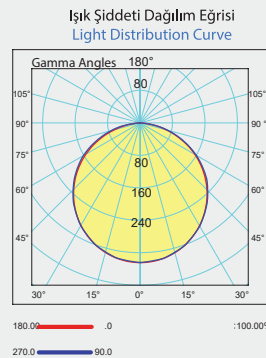

## LİNEER AYDINLATMA SERİSİ

### LINEER LIGHTING SERIES

# GTI-CLK



GTI-CLK15

GTI-CLK30

GTI-CLK45



### Teknik Özellikler - Technical Specifications

- Ürünün gövdesi; alüminyum enjeksiyon
- Mükemmel termal performans
- Ömür: >50.000 saat, PF: >95%
- Giriş gerilimi : 220-240V Frekans: 50-60 Hz
- Renksel ger. ind. (CRI): >70
- Güç faktörü: >0,95
- 3 yıl garanti.
- Die-cast aluminium
- Excelant thermal performance
- Life: >50.000 h, PF:>95%
- Input voltage: 220-240V Frequency: 50-60 Hz
- Colour Ren. In(CRI): >70
- Power Fac. :>0,95
- 3 year warranty

Ürün Kodu Product Code	Güç Power (W)	Işık Akısı Lumen (lm)	Renk Sıcaklığı Color Temperatures (k)	Ürün Ağırlık Product Weight (kg)	Ürün Ebatları Product Sizes (mm)	Brüt Ağırlık Gross Weight (kg)	Kutu Ebatları Package Sizes (mm)
GTI-CLK15	15	2025	3000-6500	0,6	522x70x56	0,8	550x90x70
GTI-CLK30	30	4050	3000-6500	1,55	1045x70x56	1,9	1090x90x70
GTI-CLK45	45	6075	3000-6500	1,9	1522x700x56	2,2	1560x90x70

### Uygulama Alanları - Filed of Application



OTELLER



KORİDORLAR



ALIŞVERİŞİ  
MERKEZLERİ



MARKETLER



TOPLANTI  
SALONLARI



HASTANELER

### Montaj Şekilleri-Mounting Styles



Sarkıt



Sıvaüstü Montaj



Elektrik Tavası



Busbar

### Fotometrik Veri - Photometric Data

Işık Şiddeti Dağılım Eğrisi  
Light Distribution Curve

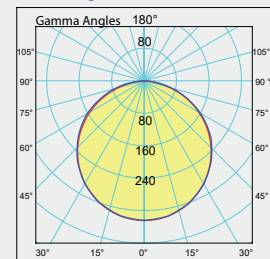

180.00° .0  
270.0° 90.0°

## DMX LİNEER AYDINLATMA SERİSİ DMX LINEER LIGHTING SERIES GTI-DMX



DMX Lineer bina, köprü, gökdelen, müze, ve tarihi yapıların iç ve dış cephelerinin aydınlatılması ve renginin değiştirilmesi amacıyla kullanılan led armatürdür.

Uygulama alanına göre farklı güçte ve lens seçenekleriyle üretilen DMX Lineer özel montaj ve ayak sistemleriyle her türlü cepheye ve yüzeye rahatça uygulanabilmektedir.

Tek sıra led dizilimine sahip ve istenilen boyda üretilmektedir. DMX Lineer kontrol edilebilir ve sabit renkli olmak üzere iki farklı tipte üretilmektedir. Kontrol edilemeyen sabit renkli armatürler, harici bir pano ihtiyacı olmaksızın 24 VAC girişli dahili güç ünitesi ile çalışmaktadır. Armatür panosu kullanıldığı durumlarda güç ve kontrol birimleri pano içerisine yerleştirilebilmektedir. Plastik gövdeye sahip olan DMX Lineer, elverişsiz dış ortam koşullarında uzun süre çalışmak üzere tasarlanmıştır ve IP67 toz ve su koruma sınıfına sahiptir.

DMX Linear is a led luminaire used to illuminate and change the color of the interior and exterior of buildings, bridges, skyscrapers, museums, and historical buildings. Produced with different power and lens options according to the application area, DMX Linear can be easily applied to any facade and surface with its special mounting and foot systems.

It has a single row LED array and is produced in the desired size. DMX is produced in two different types as Linear controllable and fixed color. Uncontrollable fixed colored luminaires operate with a 24 VAC input internal power unit without the need for an external panel. In cases where armature panel is used, power and control units can be placed in the panel. With a plastic body, DMX Linear is designed to operate for a long time in unfavorable outdoor conditions and has IP67 dust and water protection class.

### Teknik Özellikler - Technical Specifications

- İstenilen boy seçeneği
- 9W ile 144W arası güç seçenekleri
- Soğuk beyaz, Gün ışığı, Sıcak beyaz, Kırmızı, Yeşil, Mavi, Amber, Mint, Cyan, Lime, Derin kırmızı ve Royal mavi sabit renk Led seçenekleri
- DMX kontrolü ile RGB/RGBW/RGBA seçeneği
- Dahili DMX dekoder ve güç birimi ile kolay montaj imkanı
- TEk kablo ile güç ve data girişi
- Paslanmaz montaj ekipmanları
- IP67 koruma sınıfına uygunluk
- Opsiyonel gövde rengi
- Desired size option
- Power options between 9W and 144W
- Cool white, Daylight, Warm white, Red, Green, Blue, Amber, Mint, Cyan, Lime, Deep red and Royal blue fixed color Led options
- RGB / RGBW / RGBA option with DMX control
- Easy installation with internal DMX decoder and power unit
- Power and data input with TEk cable
- Stainless assembly equipment
- Compliance with IP67 protection class
- Optional body color



### Teknik Çizim Technical Drawing

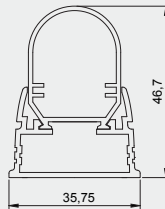

Soğuk Beyaz  
6500K



Gün Işığı  
4000K



Sıcak Beyaz  
2700K

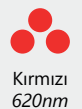

Kırmızı  
620nm



Yeşil  
530nm



Mavi  
470nm



Amber  
590nm



Cyan  
500nm



Lime  
566nm

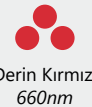

Derin Kırmızı  
660nm



A long, empty hallway with a grid ceiling and recessed lighting fixtures. The hallway is illuminated by a series of circular recessed lights, creating a bright and clean atmosphere. The walls are white, and the floor is a light-colored tile. The perspective is from the end of the hallway, looking down its length.

# DOWNLIGHT AYDINLATMA SERİSİ

## DOWNLIGHT LIGHTING SERIES

# DOWNLIGHT AYDINLATMA SERİSİ

## DOWNLIGHT LIGHTING SERIES

### GTI-ADL

GTI-ADL12

GTI-ADL18

GTI-ADL24



#### Teknik Özellikler - Technical Specifications

- Ürünün gövdesi; alüminyum enjeksiyon
- Mükemmel termal performans
- Ömür: >50.000 saat, PF: >95%
- Giriş gerilimi : 220-240V Frekans: 50-60 Hz
- Renksel ger. ind. (CRI): >70
- Güç faktörü: >0,95
- 3 yıl garanti.
- Die-cast aluminium
- Excelant thermal performance
- Life: >50.000 h, PF:>95%
- Input voltage: 220-240V Frequency: 50-60 Hz
- Colour Ren. In(CRI): >70
- Power Fac. :>0,95
- 3 year warranty

Ürün Kodu Product Code	Güç Power (W)	Işık Akısı Lumen (lm)	Renk Sıcaklığı Color Temperatures (k)	Ürün Ağırlık Product Weight (kg)	Ürün Ebatları Product Sizes (mm)	Brüt Ağırlık Gross Weight (kg)	Kutu Ebatları Package Sizes (mm)
GTI-ADL12	12	1620	3000-6500	0,5	190*170*55	0,75	200*200*80
GTI-ADL18	18	2430	3000-6500	0,5	190*170*55	0,75	200*200*80
GTI-ADL24	24	3240	3000-6500	0,5	190*170*55	0,75	200*200*80

#### Opsiyonlar - Options

Acil Durum Kiti: Var (1-3 saat)  
Emergency Kit: Yes (1-3 hours)  
Dimleme Protokolü : Uygun  
Dimming Protocol: Available

#### Teknik Çizim - Technical Drawing

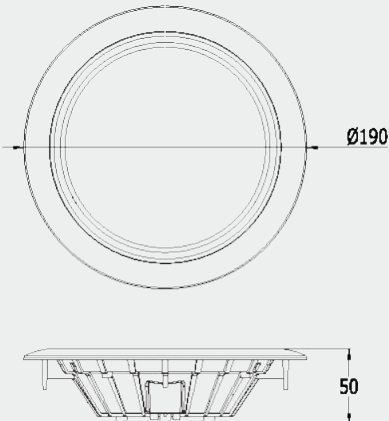

#### Uygulama Alanları - Filed of Application

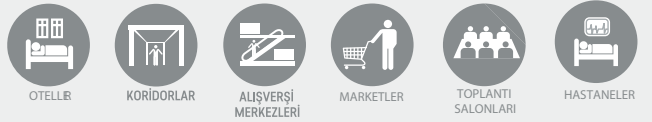

#### Fotometrik Veri - Photometric Data

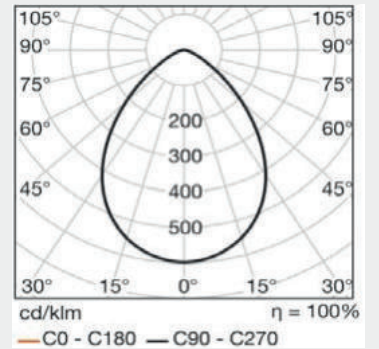
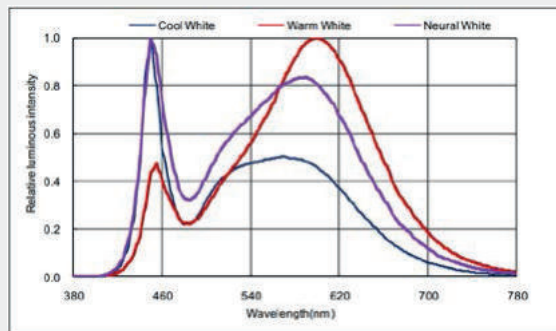



**ACIL AYDINLATMA SERİSİ**  
**EMERGENCY LIGHTING SERIES**

## ACİL AYDINLATMA SERİSİ EMERGENCY LIGHTING SERIES GTI-ACL



### ÜRÜN ÖZELLİKLERİ

- Tek taraflı veya çift taraflı montaj seçenekleri
- Asma tavana ankastre kapak ile sivaüstü tavana çelik tel askı zinciri veya duvara mafsallı braket ile montaj imkanı
- ABS V0 yanmaz plastik gövde
- Çift yüzlü, serigrafi baskılı veya pantograf oymalı, yandan aydınlatmalı sarkıt pleksiglaslı yönlendirme tahtası,
- Endüstriyel yüksek sıcaklık tipi, kablolu ve polarize konektörlü Ni-Cd pil
- Ni-Cd batarya için aşırı şarj ve deşarja karşı korumalı
- Test butonu, yeşil LED şebeke ve şarj göstergesi
- A Sınıfı enerji tüketimi
- TS 8710 / EN 60598-2-22 ve CE normlarına uygundur.

### TEKNİK ÖZELLİKLER

- Çalışma gerilimi(V) : 220-230V AC 50-60Hz
- Güç (W) : LED 2W
- Çalışma sıcaklığı : -50C... +500C
- Koruma sınıfı : IP54
- İzolasyon sınıfı : Sınıf II
- Şarj süresi : 24 saat

### TEKNİK ÇİZİMLER / TECHNICAL DRAWINGS

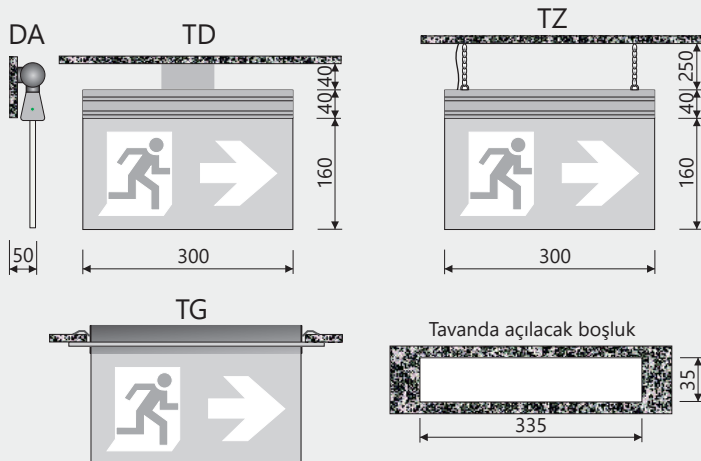

### PRODUCT FEATURES

- Single-sided or fenced-sided mounting options
- Possibility of mounting to the surface ceiling with a steel wire with a hanging chain or a wall bracket with a built-in suspended ceiling cover
- ABS V0 fireproof plastic body
- Directional board with fencing, screen printed or pantograph engraving, illuminated from the side, pendant plexiglass
- Industrial high temperature type Ni-Cd battery with cable and polarized connector
- Protected against over charge and discharge for Ni-Cd battery
- Test button, green LED mains and charge indicator
- Class A energy consumption
- Conforms to TS 8710 / EN 60598-2-22 and CE norms

### TECHNICAL DRAWING

- Operating voltage (V) : 220-230V AC 50-60Hz
- Power (W) : LED 2W
- Operating temperature : -50C... +500C
- Protection class : IP 54
- Insulation Class : Sınıf II
- Charging time : 24 Hours



Tavana gömme montaj aparatı  
Ceiling recessed mounting bracket

# ACİL AYDINLATMA SERİSİ

## EMERGENCY LIGHTING SERIES

### GTI-ACL



#### UYGULAMA ALANLARI / FİLED OF APPLICATIONS



#### ÜRÜN SEÇİM KRİTERLERİ

- Işık kaynağı : LED (L)
- Çalışma modu : Sürekli Yazma (M)
- Yüz Sayısı : Tek taraflı (1)  
Çift taraflı (2)
- Montaj Şekli : Arkadan Duvar (DA)  
Kutuptan tavana (TD)  
Tavana gömme (TG)  
Tavana Zincir (TZ)
- Acil durumda yanma süresi : 3 Saat (3H)
- Pistogram Seçeneği : P1, P2 ... P7 \* serigraf baskı  
R1, R2 ... R7 \* router oyma

#### PRODUCT SELECTION CRITERIA

- Source of light : LED (L)
- Operating mode : Steady Burning (M)
- Number of Faces : Single-sided (1)  
Double-sided (2)
- Mounting Type : Wall from behind (DA)  
Pole to ceiling (TD)  
Recessed in ceiling (TG)  
Chain to Ceiling (TZ)
- Duration of burning in emergency : 3 Hours (3H)
- Pistogram Option : P1, P2 ... P7 \* silk screen printing  
R1, R2 ... R7 \* router carving

#### PİSTOGRAMLAR / PISTOGRAMS

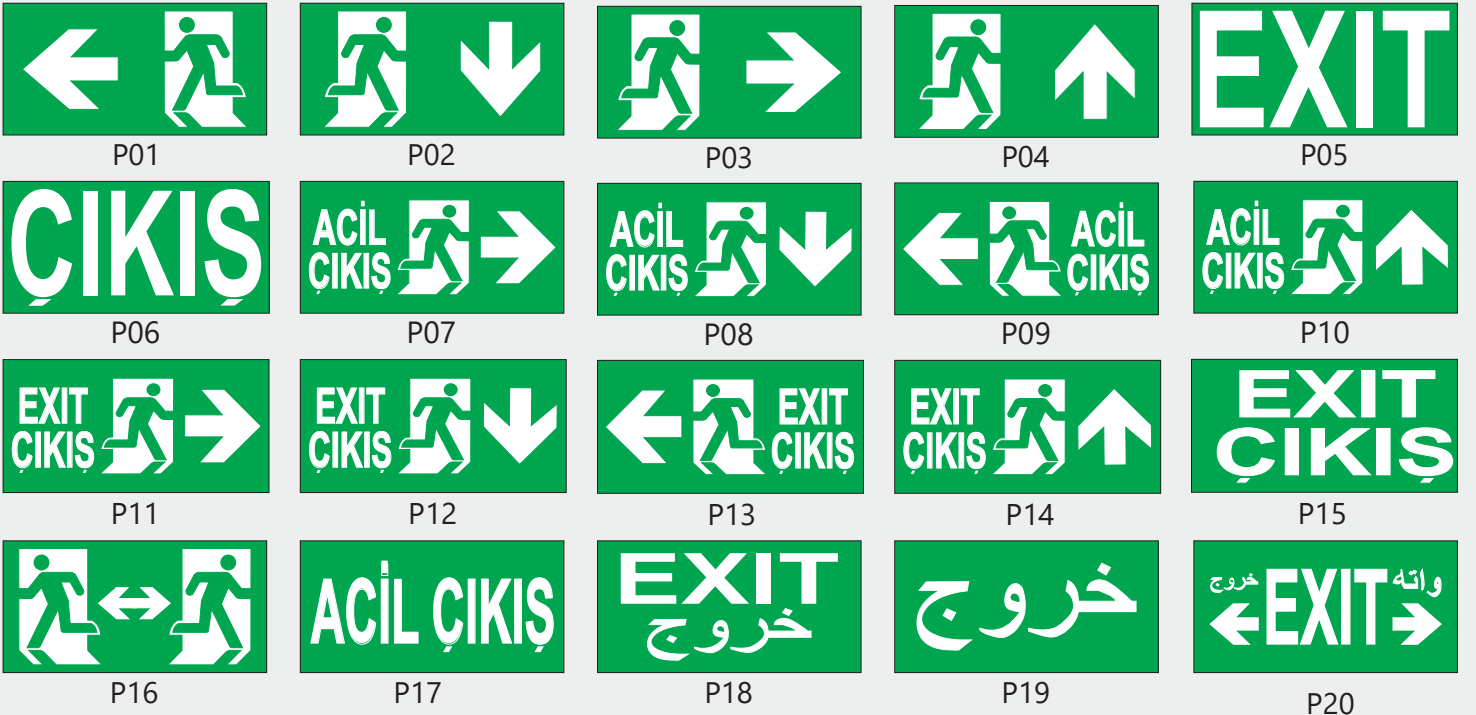

# LED ÜRÜN KATALOĐU

LED Product Catalogue

# LiON

ENERJİ SAN. LTD. ŐTİ.



satis3@licon.com.tr  
licon@licon.com.tr



+90 530 434 90 06  
+90 236 233 88 67



Güzelyurt Mah. Tekstilciler Sanayi Sitesi  
5769 Sk. No:24/A Manisa/Türkiye